

'PR' CLIP



The PANDROL® 'PR' fastening is the original PANDROL rail clip. Millions of these clips are in service in North America and around the world. This proven geometric design offers a strong, resilient rail fastening that provides a clamping force of 2,000 pounds, excellent resistance to rail rollover and longitudinal restraint.

PANDROL® 'PR' fastenings are used on wood and concrete ties and for slab track applications. The 'PR' clip is driven parallel to the rail and is easily installed mechanically or manually.

SPECIFICATIONS:

- Made from high quality spring steel bar stock
- Bar Diameter: 7/8"
- Approximate Shipping Weight: 2.75 lbs.
- Normally packed 30 to a bag

Clip	'PR' 633
Bar Diameter	7/8"
Nominal Toe Load	2,000 lbs.
Working Deflection	.56"
Nominal Rail Seat Clamping Force	4,000 lbs.
Surface area in contact with insulator or rail	.67 sq. in.

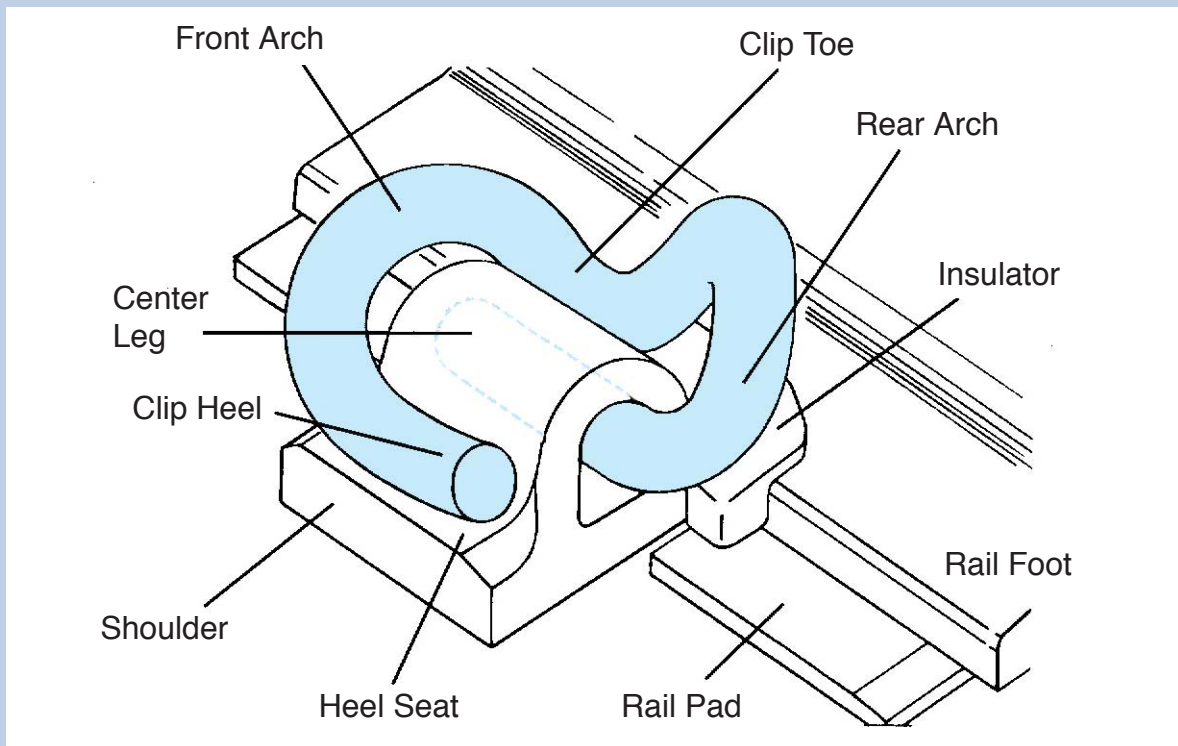
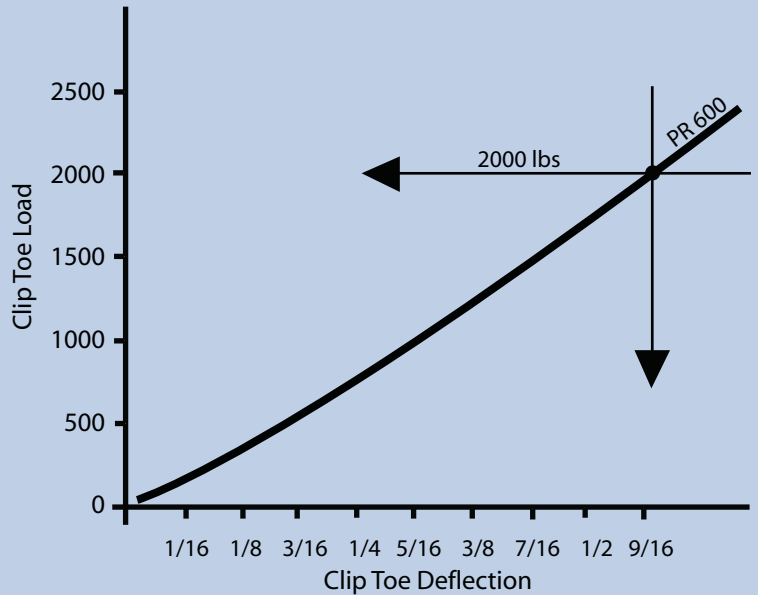

Pandrol USA, LP
 501 Sharptown Road
 P.O. Box 367
 Bridgeport, NJ 08014
 (856) 467-3227
 (800) 221-CLIP
 FAX (856) 467-2994
www.pandrolusa.com

ISO 9001: 2000 Certified



Pandrol Canada Limited
 6910 - 34th Street
 P.O. Box 367
 Edmonton, AB
 T6B 2X2
 (780) 413-4281
 FAX (780) 413-4283
www.pandrolcanada.ca

ISO 9001: 2000 Certified