

TECHNICAL INFORMATION

ALL DIMENSIONS IN INCHES	ORIGINAL SCALE 3/4
--------------------------	--------------------

GENERAL TOLERANCES UNLESS OTHERWISE STATED
 TO :± > :±
 > TO :± ANGLES:±
 MATERIAL/FINISH

DRAWN WITH REFERENCE TO BS8888
 IF IN DOUBT, ASK!
 DO NOT SCALE

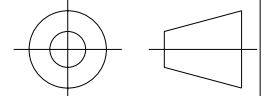

COPY STATUS

THIS COPY, ALTHOUGH CORRECT AT THE DATE OF ISSUE, WILL NOT BE KEPT UP TO DATE PANDROL BRAND COMPONENTS ARE UNDER CONTINUOUS DEVELOPMENT. SPECIFIC VARIANTS USUALLY NEED TO BE DEVELOPED TO SUIT SPECIFIC APPLICATIONS AND COMPONENT PARTS WITHIN AN ASSEMBLY NEED TO BE MATCHED TO EACH OTHER TO ENSURE SUCCESSFUL PERFORMANCE. CUSTOMERS AND THEIR PROFESSIONAL ADVISERS INTENDING TO SPECIFY PANDROL BRAND ASSEMBLIES SHOULD REFER TO PANDROL TO CHECK THAT THE DRAWINGS USED AND THE COMPONENTS PROPOSED ARE STILL CURRENT AND CORRECT FOR THE INTENDED APPLICATION. MANUFACTURERS SHOULD CHECK THAT THE DRAWING NUMBER AND ISSUE CODE CORRESPONDS EXACTLY TO THE CODES ON THE PANDROL PURCHASE ORDER

ISSUE STATUS

UNTIL THIS DRAWING IS SIGNED APPROVED BY AN AUTHORISED SIGNATORY, THIS ISSUE MUST BE REGARDED AS **PROVISIONAL**, RELEASED FOR DISCUSSION AND THE DEVELOPMENT OF SAMPLES ONLY.

ISSUE CODE 1	DRAWN	DATE
	J. MEAGHER	06OCT05
	CHECKED	DATE
	APPROVED	DATE

DI/ECR NUMBER 5039	ORIGINAL DRAWN BY: J. MEAGHER DATE: 06OCT05
-----------------------	--



501 SHARPTOWN ROAD
 P.O. BOX 367, BRIDGEPORT
 NEW JERSEY 08014, USA
 TELEPHONE: (856) 467-3227
 FACSIMILE: (856) 467-2994

TITLE
**DETAIL WELDMENT
 DRAWING FOR
 PRESSED STEEL / FORGED
 NON-INSULATED SHOULDERS**

DRAWING NO.
USK-1136

FILE REF. No.	SHEET
	1 OF 4 A2

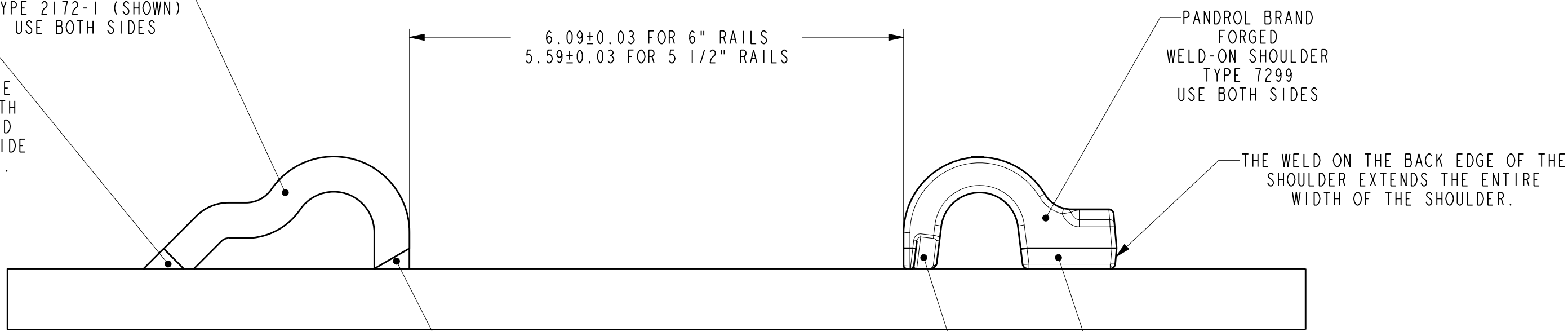
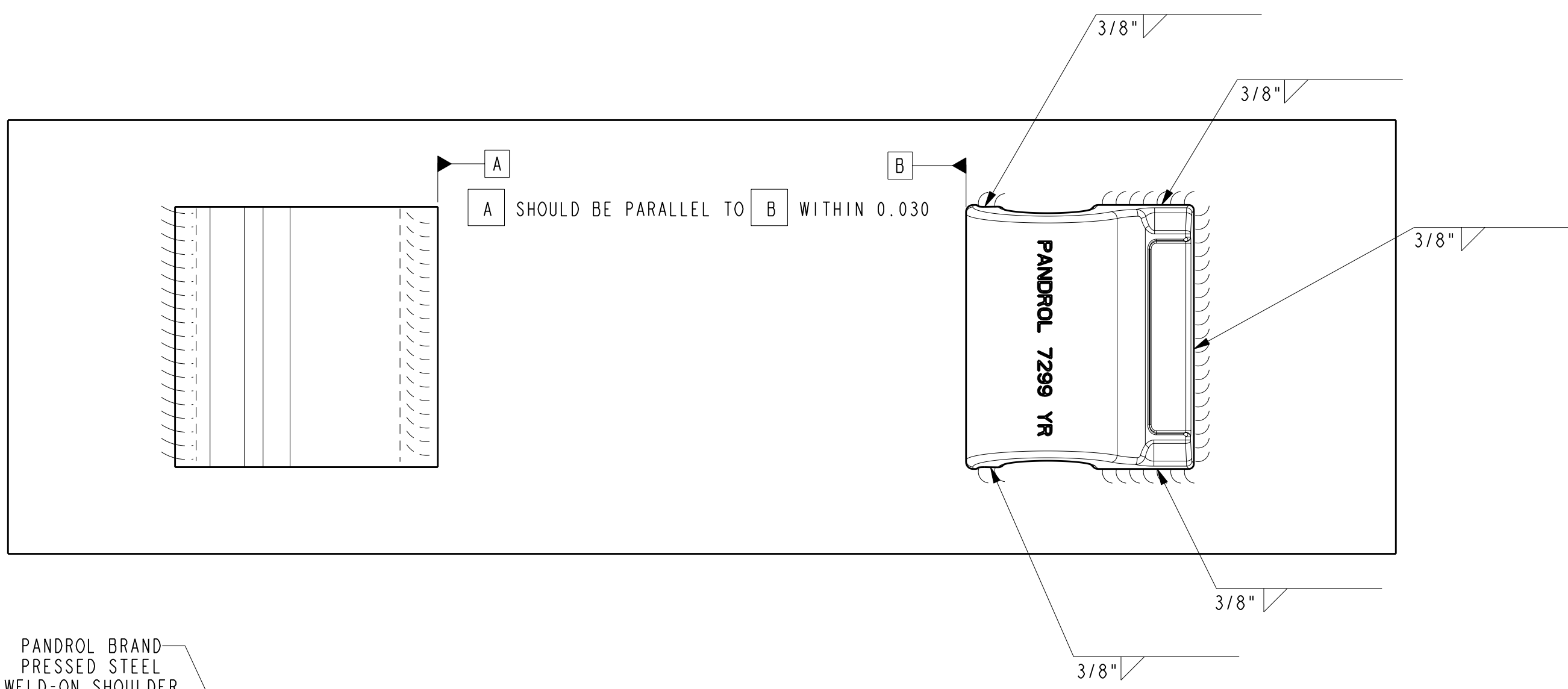

THE WELD ON THE BACK EDGE OF THE SHOULDER EXTENDS THE ENTIRE WIDTH OF THE SHOULDER. THE WELD SHOULD BE 3/8" FILLET MINIMUM, AND PROVIDE ADEQUATE PENETRATION BOTH PARTS.

PANDROL BRAND PRESSED STEEL WELD-ON SHOULDER TYPE 2172-1 (SHOWN) USE BOTH SIDES

PANDROL BRAND FORGED WELD-ON SHOULDER TYPE 7299 USE BOTH SIDES

THE WELD ON THE BACK EDGE OF THE SHOULDER EXTENDS THE ENTIRE WIDTH OF THE SHOULDER.

THE WELD ON THE FRONT OF THE SHOULDER AT THE BEVEL SHOULD FILL THE GAP APPROXIMATELY 3/8", BUT NOT OVERFLOW INTO RAIL SEAT AREA. GRIND FACE OF WELD IN RAIL SEAT TO BE FLUSH WITH SURFACE OF SHOULDERS. ALSO GRIND WELD ON CORNERS OF SHOULDERS TO PERMIT FULL SURFACE BEARING FOR RAIL PAD (IF REQUIRED). CARE IN GRINDING MUST BE EXERCISED TO PREVENT ANY NOTCHING OF THE WELD OR SHOULDER.

THE WELD ALONG BOTH SIDES OF THE SHOULDER SHALL BEGIN 1/4" BEHIND THE BACK EDGE OF THE CLIP HOUSING AND CONTINUE TO THE BACK EDGE.

THE WELDS ON THE FRONT OF THE SHOULDER AT THE INDENTS SHOULD FILL THE INDENTS BUT NOT OVERFLOW INTO THE CLIP HOUSING.

NOTES:

1. ALL WELDS SHALL USE LOW HYDROGEN FILLER ROD 7018 OR EQUIVALENT.
2. ALL WELDS SHOULD BE 3/8" FILLET WELDS MINIMUM, AND PROVIDE ADEQUATE PENETRATION INTO BOTH SHOULDER AND PLATE.
3. WELD MUST NOT INTERFERE WITH EITHER RAIL OR PANDROL CLIP.
4. RAIL SEATS SHALL BE FREE OF EXCESS WELD, SLAG AND SPLATTER.
5. SHOULDERS SHALL BE TACKED (OR CLAMPED) DOWN PRIOR TO FINAL WELDING TO PREVENT THE SHOULDER FROM RISING DURING FINAL WELDING.
6. PRE-HEAT 7299 FORGED SHOULDER TO 300°F BEFORE WELDING.

THIS DRAWING HAS COPYRIGHT WHICH IS OWNED BY PANDROL LIMITED. NEITHER THIS DRAWING ITSELF NOR ARTICLE NOR COMPONENT ILLUSTRATED THEREIN MAY BE REPRODUCED IN WHOLE OR IN PART, IN ANY FORM WHATSOEVER WITHOUT PRIOR WRITTEN AUTHORITY FROM PANDROL LIMITED. THIS DRAWING HAS BEEN DELIVERED ON THE UNDERSTANDING THAT IT IS NOT USED IN ANY WAY AGAINST THE INTERESTS OF PANDROL LIMITED AND WILL BE RETURNED ON DEMAND. "PANDROL" IS A REGISTERED TRADE MARK. "PANDROL" BRAND "PR" CLIPS TYPE "e" CLIPS AND "PANDROL FASTCLIP" ARE SUPPLIED EXCLUSIVELY BY PANDROL LIMITED, THEIR SUBSIDIARIES AND ASSOCIATES WORLDWIDE.

ISSUE CODE HISTORY	ISS	MOD	ISS	MOD	ISS	MOD
--------------------	-----	-----	-----	-----	-----	-----

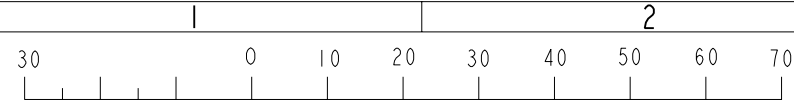

A
B
C
D
E
F
G

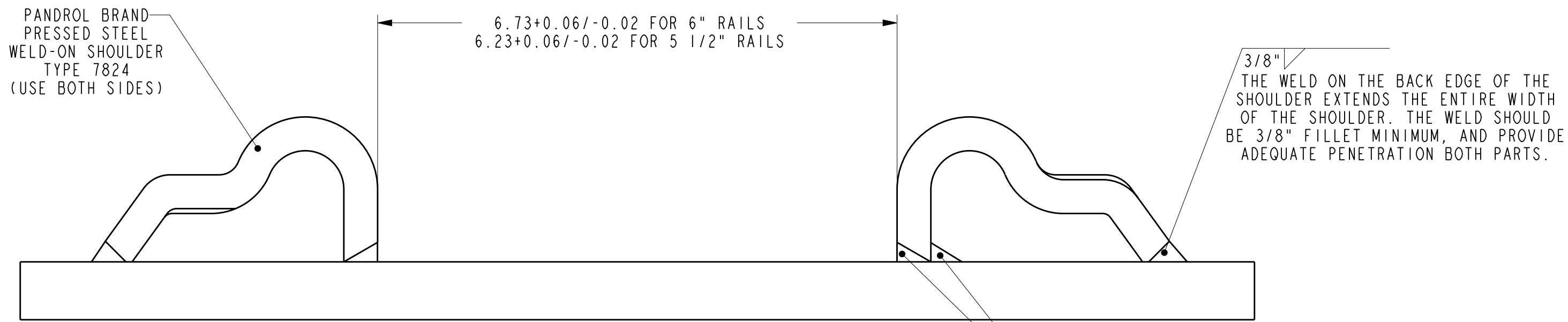
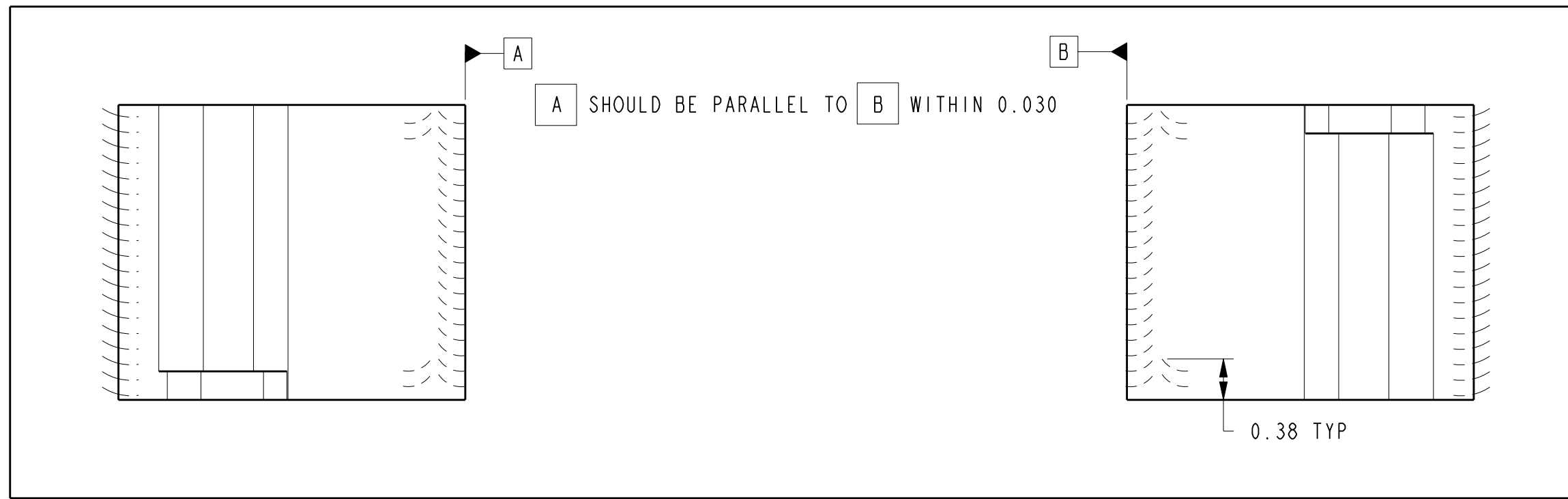

SCALE 3:4

NOTES:

1. ALL WELDS SHALL USE LOW HYDROGEN FILLER ROD 7018 OR EQUIVALENT.
2. ALL WELDS SHOULD BE 3/8" FILLET WELDS MINIMUM, AND PROVIDE ADEQUATE PENETRATION INTO BOTH SHOULDER AND PLATE.
3. WELD MUST NOT INTERFERE WITH EITHER RAIL, PANDROL CLIP OR RAIL PAD.
4. RAIL SEATS SHALL BE FREE OF EXCESS WELD, SLAG AND SPLATTER.
5. SHOULDERS SHALL BE TACKED (OR CLAMPED) DOWN PRIOR TO FINAL WELDING TO PREVENT THE SHOULDER FROM RISING DURING FINAL WELDING.

3/8"
THE WELD ON THE FRONT OF THE SHOULDER AT THE BEVEL SHOULD FILL THE GAP APPROXIMATELY 3/8", BUT NOT OVERFLOW INTO RAIL SEAT AREA. GRIND FACE OF WELD IN RAIL SEAT TO BE FLUSH WITH SURFACE OF SHOULDERS. ALSO GRIND WELD ON CORNERS OF SHOULDERS TO PERMIT FULL SURFACE BEARING FOR RAIL PAD. CARE IN GRINDING MUST BE EXERCISED TO PREVENT ANY NOTCHING OF THE WELD OR SHOULDER.

TECHNICAL INFORMATION

ALL DIMENSIONS IN INCHES	ORIGINAL SCALE 3/4
GENERAL TOLERANCES UNLESS OTHERWISE STATED	
TO :±	> :±
> TO :±	ANGLES:±
MATERIAL/FINISH	
DRAWN WITH REFERENCE TO BS8888 IF IN DOUBT, ASK! DO NOT SCALE	

COPY STATUS

THIS COPY, ALTHOUGH CORRECT AT THE DATE OF ISSUE, WILL NOT BE KEPT UP TO DATE PANDROL BRAND COMPONENTS ARE UNDER CONTINUOUS DEVELOPMENT. SPECIFIC VARIANTS USUALLY NEED TO BE DEVELOPED TO SUIT SPECIFIC APPLICATIONS AND COMPONENT PARTS WITHIN AN ASSEMBLY NEED TO BE MATCHED TO EACH OTHER TO ENSURE SUCCESSFUL PERFORMANCE. CUSTOMERS AND THEIR PROFESSIONAL ADVISERS INTENDING TO SPECIFY PANDROL BRAND ASSEMBLIES SHOULD REFER TO PANDROL TO CHECK THAT THE DRAWINGS USED AND THE COMPONENTS PROPOSED ARE STILL CURRENT AND CORRECT FOR THE INTENDED APPLICATION. MANUFACTURERS SHOULD CHECK THAT THE DRAWING NUMBER AND ISSUE CODE CORRESPONDS EXACTLY TO THE CODES ON THE PANDROL PURCHASE ORDER

ISSUE STATUS

UNTIL THIS DRAWING IS SIGNED APPROVED BY AN AUTHORISED SIGNATORY, THIS ISSUE MUST BE REGARDED AS **PROVISIONAL**, RELEASED FOR DISCUSSION AND THE DEVELOPMENT OF SAMPLES ONLY.

ISSUE CODE 1	DRAWN	DATE
	J. MEAGHER	06OCT05
	CHECKED	DATE
	APPROVED	DATE

DI/ECR NUMBER 5039	ORIGINAL DRAWN BY: J. MEAGHER DATE: 06OCT05
-----------------------	---



501 SHARPTOWN ROAD
P.O. BOX 367, BRIDGEPORT
NEW JERSEY 08014, USA
TELEPHONE: (856) 467-3227
FACSIMILE: (856) 467-2994

TITLE
**DETAIL WELDMENT
DRAWING FOR
PRESSED STEEL
INSULATED SHOULDERS**

DRAWING NO.
USK-1136

THIS DRAWING HAS COPYRIGHT WHICH IS OWNED BY PANDROL LIMITED. NEITHER THIS DRAWING ITSELF NOR ARTICLE NOR COMPONENT ILLUSTRATED THEREIN MAY BE REPRODUCED IN WHOLE OR IN PART, IN ANY FORM WHATSOEVER WITHOUT PRIOR WRITTEN AUTHORITY FROM PANDROL LIMITED. THIS DRAWING HAS BEEN DELIVERED ON THE UNDERSTANDING THAT IT IS NOT USED IN ANY WAY AGAINST THE INTERESTS OF PANDROL LIMITED AND WILL BE RETURNED ON DEMAND. "PANDROL" IS A REGISTERED TRADE MARK. "PANDROL" BRAND "PR" CLIPS TYPE "e" CLIPS AND "PANDROL FASTCLIP" ARE SUPPLIED EXCLUSIVELY BY PANDROL LIMITED, THEIR SUBSIDIARIES AND ASSOCIATES WORLDWIDE.

ISSUE CODE HISTORY	ISS	MOD	ISS	MOD	ISS	MOD
--------------------	-----	-----	-----	-----	-----	-----

FILE REF. No.	SHEET
	2 OF 4 A2

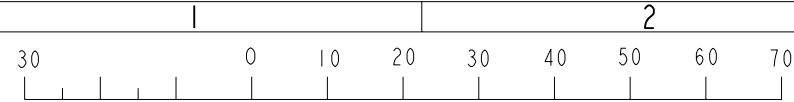

A

B

C

D

E

F

G

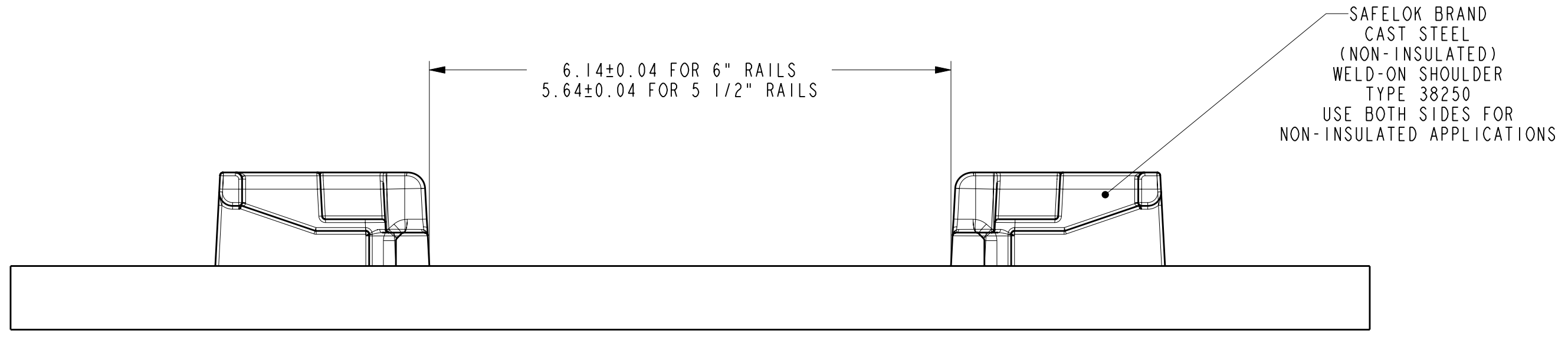
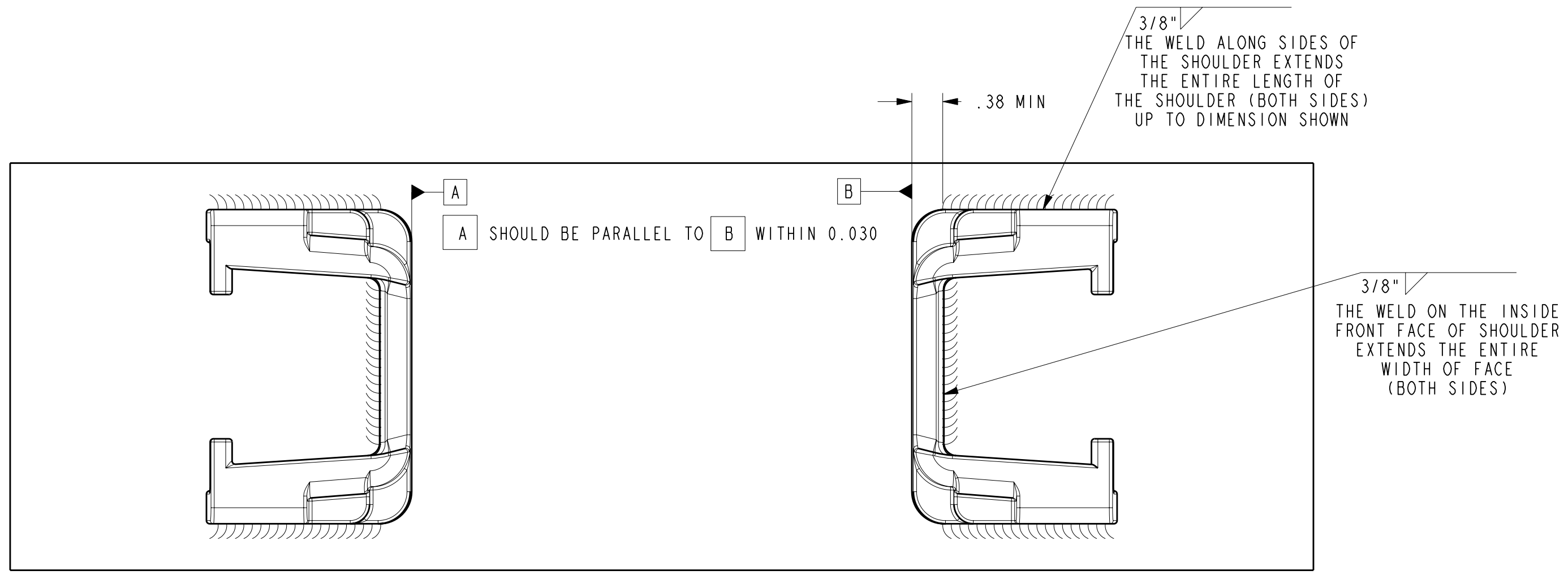

NOTES:

1. ALL WELDS SHALL USE LOW HYDROGEN FILLER ROD 7018 OR EQUIVALENT.
2. ALL WELDS SHOULD BE 3/8" FILLET WELDS MINIMUM, AND PROVIDE ADEQUATE PENETRATION INTO BOTH SHOULDER AND PLATE.
3. WELD MUST NOT INTERFERE WITH EITHER RAIL OR SAFELOK CLIP.
4. RAIL SEATS SHALL BE FREE OF EXCESS WELD, SLAG AND SPLATTER.
5. SHOULDERS SHALL BE TACKED (OR CLAMPED) DOWN PRIOR TO FINAL WELDING TO PREVENT THE SHOULDER FROM RISING DURING FINAL WELDING.
6. PRE-HEAT SHOULDERS TO 300°F BEFORE WELDING.

TECHNICAL INFORMATION

ALL DIMENSIONS IN INCHES	ORIGINAL SCALE 3/4
GENERAL TOLERANCES UNLESS OTHERWISE STATED	
TO :±	> :±
> TO :±	ANGLES:±
MATERIAL/FINISH	
DRAWN WITH REFERENCE TO BS8888 IF IN DOUBT, ASK! DO NOT SCALE	

COPY STATUS

THIS COPY, ALTHOUGH CORRECT AT THE DATE OF ISSUE, WILL NOT BE KEPT UP TO DATE PANDROL BRAND COMPONENTS ARE UNDER CONTINUOUS DEVELOPMENT. SPECIFIC VARIANTS USUALLY NEED TO BE DEVELOPED TO SUIT SPECIFIC APPLICATIONS AND COMPONENT PARTS WITHIN AN ASSEMBLY NEED TO BE MATCHED TO EACH OTHER TO ENSURE SUCCESSFUL PERFORMANCE. CUSTOMERS AND THEIR PROFESSIONAL ADVISERS INTENDING TO SPECIFY PANDROL BRAND ASSEMBLIES SHOULD REFER TO PANDROL TO CHECK THAT THE DRAWINGS USED AND THE COMPONENTS PROPOSED ARE STILL CURRENT AND CORRECT FOR THE INTENDED APPLICATION. MANUFACTURERS SHOULD CHECK THAT THE DRAWING NUMBER AND ISSUE CODE CORRESPONDS EXACTLY TO THE CODES ON THE PANDROL PURCHASE ORDER

ISSUE STATUS

UNTIL THIS DRAWING IS SIGNED APPROVED BY AN AUTHORISED SIGNATORY, THIS ISSUE MUST BE REGARDED AS **PROVISIONAL**, RELEASED FOR DISCUSSION AND THE DEVELOPMENT OF SAMPLES ONLY.

ISSUE CODE	DRAWN	DATE
1	J. MEAGHER	06OCT05
	CHECKED	DATE
	APPROVED	DATE

DI/ECR NUMBER	ORIGINAL DRAWN
5039	BY: J. MEAGHER DATE: 06OCT05



501 SHARPTOWN ROAD
P.O. BOX 367, BRIDGEPORT
NEW JERSEY 08014, USA
TELEPHONE: (856) 467-3227
FACSIMILE: (856) 467-2994

TITLE
**DETAIL WELDMENT
DRAWING FOR
SAFELOK NON-INSULATED
CAST SHOULDERS**

DRAWING NO.
USK-1136

THIS DRAWING HAS COPYRIGHT WHICH IS OWNED BY PANDROL LIMITED. NEITHER THIS DRAWING ITSELF NOR ARTICLE NOR COMPONENT ILLUSTRATED THEREIN MAY BE REPRODUCED IN WHOLE OR IN PART, IN ANY FORM WHATSOEVER WITHOUT PRIOR WRITTEN AUTHORITY FROM PANDROL LIMITED. THIS DRAWING HAS BEEN DELIVERED ON THE UNDERSTANDING THAT IT IS NOT USED IN ANY WAY AGAINST THE INTERESTS OF PANDROL LIMITED AND WILL BE RETURNED ON DEMAND. "PANDROL" IS A REGISTERED TRADE MARK. "PANDROL" BRAND "PR" CLIPS TYPE "e" CLIPS AND "PANDROL FASTCLIP" ARE SUPPLIED EXCLUSIVELY BY PANDROL LIMITED, THEIR SUBSIDIARIES AND ASSOCIATES WORLDWIDE.

ISSUE CODE HISTORY	ISS	MOD	ISS	MOD	ISS	MOD

FILE REF. No.	SHEET
	3 OF 4 A2

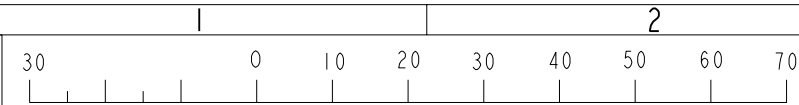

A

B

C

D

E

F

G

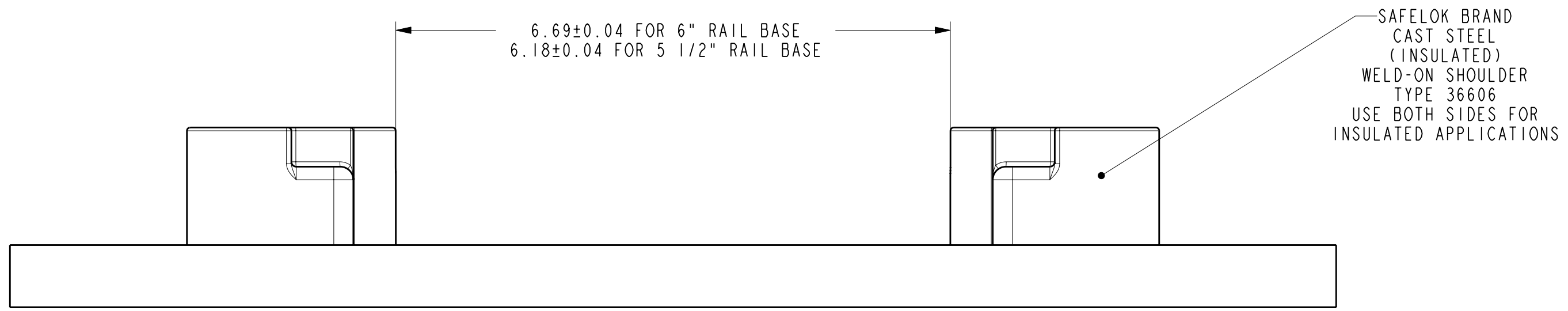
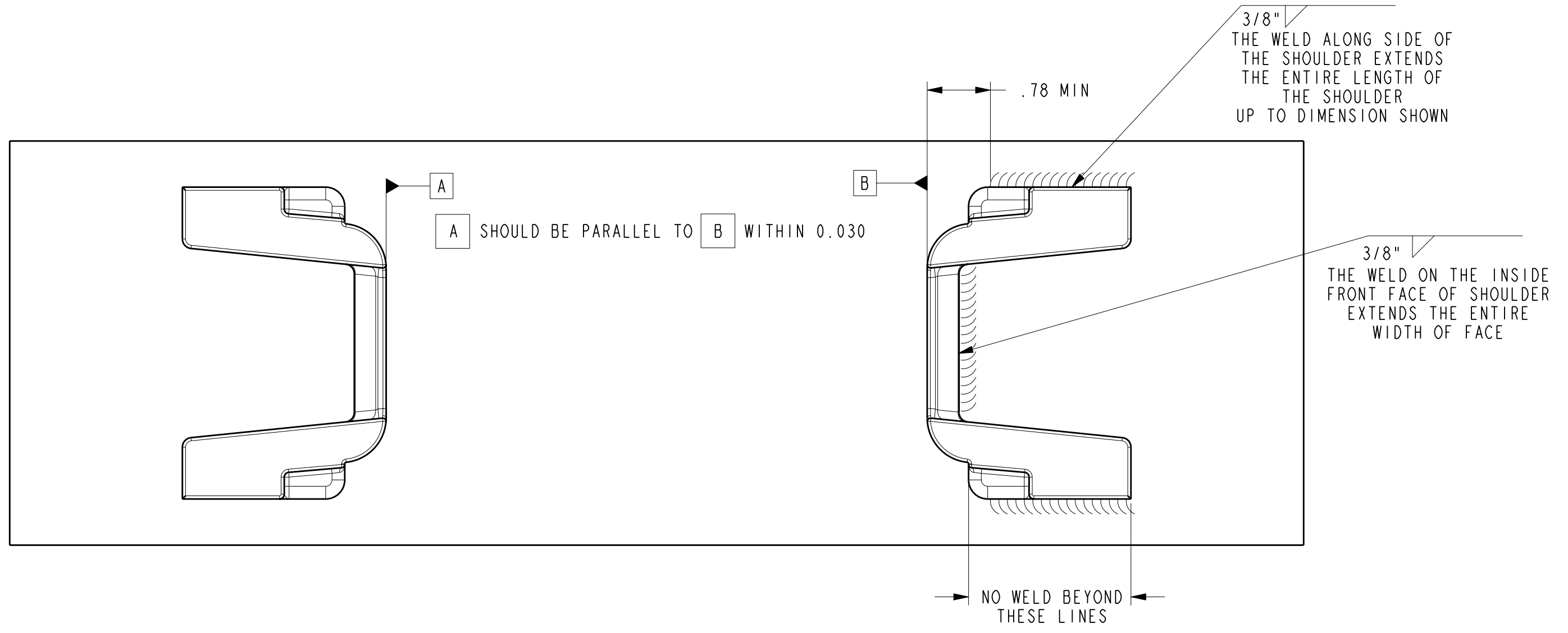

SCALE 3:4

NOTES:

1. ALL WELDS SHALL USE LOW HYDROGEN FILLER ROD 7018 OR EQUIVALENT.
2. ALL WELDS SHOULD BE 3/8" FILLET WELDS MINIMUM, AND PROVIDE ADEQUATE PENETRATION INTO BOTH SHOULDER AND PLATE.
3. WELD MUST NOT INTERFERE WITH EITHER RAIL, SAFELOK CLIP OR RAIL PAD.
4. RAIL SEATS SHALL BE FREE OF EXCESS WELD, SLAG AND SPLATTER.
5. SHOULDERS SHALL BE TACKED (OR CLAMPED) DOWN PRIOR TO FINAL WELDING TO PREVENT THE SHOULDER FROM RISING DURING FINAL WELDING.
6. PRE-HEAT SHOULDERS TO 300°F BEFORE WELDING.

TECHNICAL INFORMATION

ALL DIMENSIONS IN INCHES	ORIGINAL SCALE 3/4
GENERAL TOLERANCES UNLESS OTHERWISE STATED	
TO :±	> :±
> TO :±	ANGLES:±
MATERIAL/FINISH	

DRAWN WITH REFERENCE TO BS8888 IF IN DOUBT, ASK!
DO NOT SCALE

COPY STATUS

THIS COPY, ALTHOUGH CORRECT AT THE DATE OF ISSUE, WILL NOT BE KEPT UP TO DATE PANDROL BRAND COMPONENTS ARE UNDER CONTINUOUS DEVELOPMENT. SPECIFIC VARIANTS USUALLY NEED TO BE DEVELOPED TO SUIT SPECIFIC APPLICATIONS AND COMPONENT PARTS WITHIN AN ASSEMBLY NEED TO BE MATCHED TO EACH OTHER TO ENSURE SUCCESSFUL PERFORMANCE. CUSTOMERS AND THEIR PROFESSIONAL ADVISERS INTENDING TO SPECIFY PANDROL BRAND ASSEMBLIES SHOULD REFER TO PANDROL TO CHECK THAT THE DRAWINGS USED AND THE COMPONENTS PROPOSED ARE STILL CURRENT AND CORRECT FOR THE INTENDED APPLICATION. MANUFACTURERS SHOULD CHECK THAT THE DRAWING NUMBER AND ISSUE CODE CORRESPONDS EXACTLY TO THE CODES ON THE PANDROL PURCHASE ORDER

ISSUE STATUS

UNTIL THIS DRAWING IS SIGNED APPROVED BY AN AUTHORISED SIGNATORY, THIS ISSUE MUST BE REGARDED AS **PROVISIONAL**, RELEASED FOR DISCUSSION AND THE DEVELOPMENT OF SAMPLES ONLY.

ISSUE CODE 1	DRAWN	DATE
	J. MEAGHER	06OCT05
	CHECKED	DATE
	APPROVED	DATE

DI/ECR NUMBER 5039	ORIGINAL DRAWN BY: J. MEAGHER DATE: 06OCT05
-----------------------	--



501 SHARPTOWN ROAD
P.O. BOX 367, BRIDGEPORT
NEW JERSEY 08014, USA
TELEPHONE: (856) 467-3227
FACSIMILE: (856) 467-2994

TITLE
**DETAIL WELDMENT
DRAWING FOR
SAFELOK INSULATED
CAST SHOULDERS**

DRAWING NO.
USK-1136

THIS DRAWING HAS COPYRIGHT WHICH IS OWNED BY PANDROL LIMITED. NEITHER THIS DRAWING ITSELF NOR ARTICLE NOR COMPONENT ILLUSTRATED THEREIN MAY BE REPRODUCED IN WHOLE OR IN PART, IN ANY FORM WHATSOEVER WITHOUT PRIOR WRITTEN AUTHORITY FROM PANDROL LIMITED. THIS DRAWING HAS BEEN DELIVERED ON THE UNDERSTANDING THAT IT IS NOT USED IN ANY WAY AGAINST THE INTERESTS OF PANDROL LIMITED AND WILL BE RETURNED ON DEMAND. "PANDROL" IS A REGISTERED TRADE MARK. "PANDROL" BRAND "PR" CLIPS TYPE "e" CLIPS AND "PANDROL FASTCLIP" ARE SUPPLIED EXCLUSIVELY BY PANDROL LIMITED, THEIR SUBSIDIARIES AND ASSOCIATES WORLDWIDE.

ISSUE CODE HISTORY	ISS	MOD	ISS	MOD	ISS	MOD
--------------------	-----	-----	-----	-----	-----	-----

FILE REF. No.	SHEET
	4 OF 4 A2