

ZLR SYSTEM INSTALLATION INSTRUCTIONS

The ZLR system is designed to provide lateral and rollover restraint while allowing the rail movement with temperature changes. This system is useful on bridges and aerial structures to minimize the effect of rail expansion or contraction on the structure. The ZLR system aids in thermally adjusting the rail to a neutral temperature while keeping the rail in the rail seat.

The ZLR rail fastening system consists of a PR633 series clip and a toe plate. Consult the drawing below for proper clip and toe plate orientation.

First, check that the rail is fully seated in the tie plate. Next, place the toe plate with the coined edge tight against the edge of the tie plate. Place the clip in the housing and strike the rear of the clip with a sledge hammer. The clip is fully driven when the end of the heel is aligned with the inner coined line of the toe plate. Check to see that there is a gap between the toe plate and the rail base when the plate is contacting the heel of the shoulder.

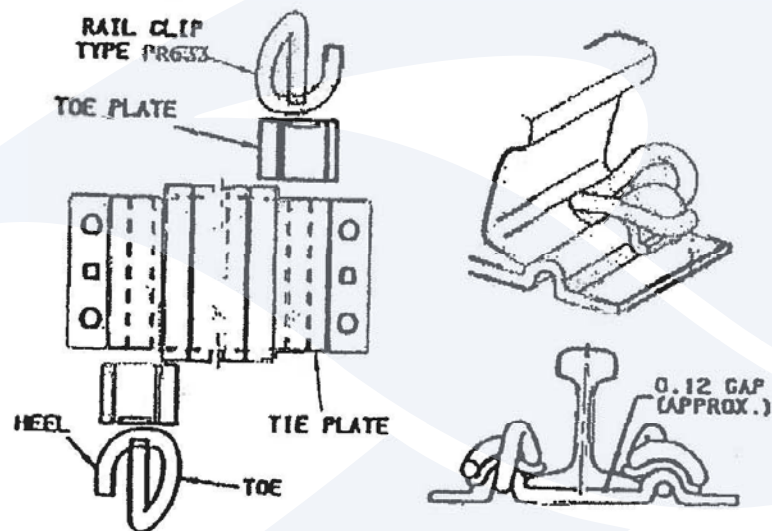

Note: The above drawing depicts right-hand style PR clips and toe plates. The ZLR system normally uses a PR style clip but in certain circumstances can use a special 'e' clip. Consult Pandrol USA if further instruction or product identification is required.

